

OM-VOLGA-FV REMOTE

OPEN MERCHANDISERS

Remote Open Front Multideck Merchandiser

Standard features

- Remote Open Merchandiser
- 2 rows shelves + Base
- Steel Shelves
- Externally Equalized TXV
- Thermostat Electronic Control
- Manual Night Curtain
- Price Tag Holder
- PVC labelling Profiles
- Bar led for top canopy and undershelf lighting
- Angled Mirrors On Top Shelf
- Wellington ERC2 electronic fan motor
- Double Glazed Side Wall Left/Right or Solid Side
- Stainless Steel Evaporator Box with Heating Element and Evaporator Cover
- Electrostatic Powdered Paint For Both Interior-Exterior (choice of colors Black or White)



Dimensions

	OM-VOLGA-FV4 REMOTE	OM-VOLGA-FV6 REMOTE	OM-VOLGA-FV8 REMOTE	OM-VOLGA-FV10 REMOTE	OM-VOLGA-FV12 REMOTE
Length (inches)	49"	74"	98"	123"	148"
Amperage	1A	1A	1A	1A	1A
Power	115V 1PH 60HZ	115V 1PH 60HZ	220V 1PH 60HZ	220V 1PH 60HZ	220V 1PH 60HZ
Evaporating Temp	-5C	-5C	-5C	-5C	-5C
BTU/H	4564	6846	9127	11409	13691

Technical Drawings

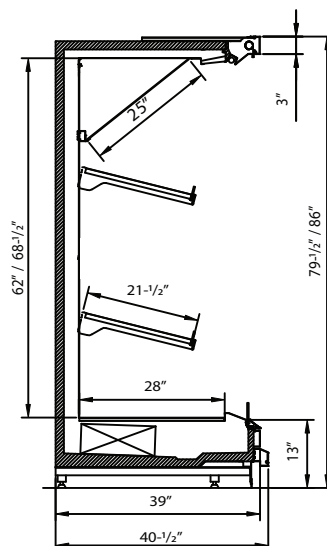

* All measurements are approximates; * Specifications are subject to change without notice; * All equipment are designed to operate in a controlled environment below 75°F (+24°C) temperature and HR 55% relative humidity;