

## OM-DRFV ( 2 rows shelves + Base )

### OPEN MERCHANDISERS - FRUIT AND VEGETABLES

#### Remote Open Front Multideck Merchandiser

##### Standard features

- Remote Open Merchandiser
- Externally Equalized TXV
- Thermostat Electronic Control
- Manual Night Curtain
- LED Lights
- Wellington ERC2 electronic fan motor
- Stainless Steel Bottom Floor and Fan Cover,  
Evaporator Box with Heating Element and Evaporator Cover
- Electrostatic Powdered Paint For Both Interior-Exterior (choice of colors Black or White)

##### Dimensions

Model	OM-DRFV-4	OM-DRFV-6	OM-DRFV-8	OM-DRFV-10	OM-DRFV-12
Length (inches)	50"	74"	99"	123"	148"
Depth (inches)	39.4"	39.4"	39.4"	39.4"	39.4"
BTU per foot	1415	1415	1415	1415	1415
Power	220V 60HZ 1ph	220V 60HZ 1ph	220V 60HZ 1ph	220V 60HZ 1ph	220V 60HZ 1ph
Amperage	0.28A	0.41A	0.56A	0.69A	0.85A
Evaporating Temp	-4C	-4C	-4C	-4C	-4C

Above mentioned measurement are from internal part of the equipment. Side panel will be extra Add approximately 2" each side for side panel thickness.

##### Technical Drawings

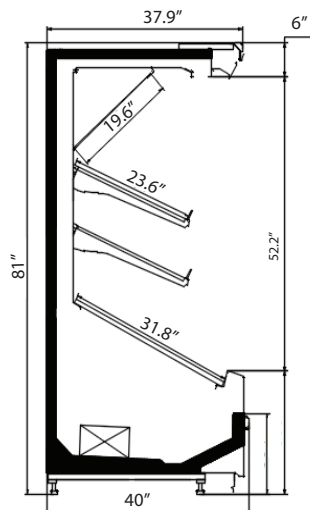

\* Customizable options available; \* Multiple shelves available; \* All measurements are approximates; \* Specifications are subject to change without notice; \* All equipment are designed to operate in a controlled environment below 75°F (+24°C) temperature and HR 55% relative humidity;

