

OM-BERMUDA REMOTE

ISLAND FREEZERS - REMOTE

Single Island Freezer Remote

Standard features

- Remote Refrigeration
- Manual Night Curtain
- Price Tag Holder
- Wire Dividers, Wire Floor
- Triple Glazed Side Wall Right/Left
- Superstructure With Led Lighting
- Externally Equalized TXV
- Thermostat Electronic Control
- Wellington ERC2 Electronic Fan Motor
- Stainless Steel Bottom Floor
- Stainless Steel Evaporator Box with Heating Element and Evaporator Cover
- Electrostatic Powdered Paint For Both Interior-Exterior (colors Black or White)
- Optional Shelves Available

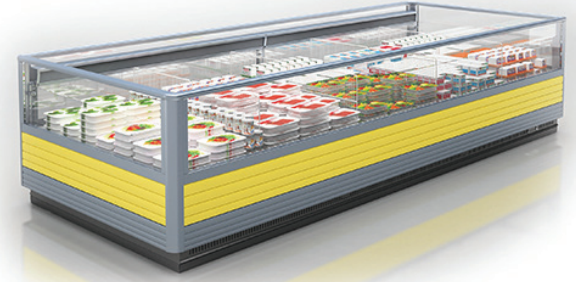

Dimensions

Depth (42.5")	OM-BERMUDA6-1 REMOTE	OM-BERMUDA6-2 REMOTE	OM-BERMUDA8 REMOTE	OM-BERMUDA12 REMOTE
Length (inches)	74"	75"	98"	148"
Depth (inches)	42.5"	42.5"	42.5"	42.5"
Amperage	5A	10A	15A	22A
Power	220V 1PH 60HZ	220V 1PH 60HZ	220V 1PH 60HZ	220V 1PH 60HZ
Evaporating Temp	-35C	-35C	-35C	-35C
BTU/H	1919	1960	2559	3839

Technical Drawings

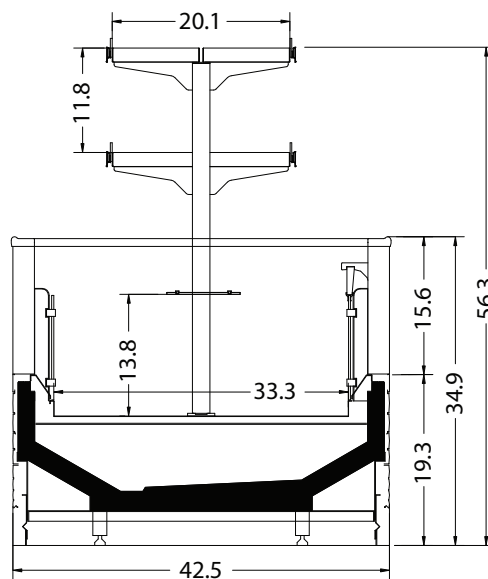

* All measurements are approximates; * Specifications are subject to change without notice; * All equipment are designed to operate in a controlled environment below 75°F (+24°C) temperature and HR 55% relative humidity;