

Display Case

CD-2-HC

Features

- * Low-velocity fan cooling system to prevent food dehydration
- * Self-evaporation water tray
- * Dixell digital temperature controller & defrost timer
- * Rear glass doors for easy access
- * 2 glass shelves with chrome-plated frames
- * LED interior lighting on each level
- * Four integrated caster wheels
- * Interior temperature range: 2°C - 6°C
- * 115V, 60Hz



Technical Drawing

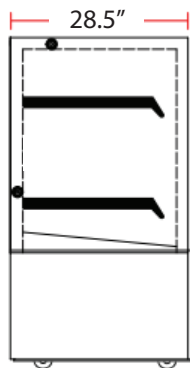
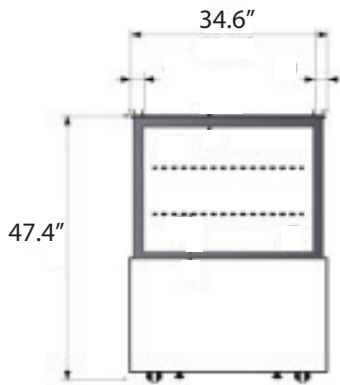

Model	Dimension W x D x H	Weight (lbs / kg)
CD900-2-HC	34.6" x 28.5" x 47.4"	353/160
CD1200-2-HC	46.4" x 28.5" x 47.4"	441/200
CD1500-2-HC	59" x 28" x 47"	507/230
CD1800-2-HC	70" x 28" x 47"	552/250

Voltage

- CD900-2-HC : 115V / 1ph / 60 Hz / 4.8A
- CD1200-2-HC : 115V / 1ph / 60 Hz / 5.58A
- CD1500-2-HC : 115V / 1ph / 60 Hz / 9.96A
- CD1800-2-HC : 115V / 1ph / 60 Hz / 11.04A